



Materials and equipment

- Appropriate size DIRAX kit
- Epoxy primer kit (type S1239 or S1301 or S1301M)
- Propane torches plus accessories (or equivalent)
- Temperature measurement equipment with contact pyrometer
- Standard safety equipment as prescribed by local regulations
- Heat resistant gloves
- Painter's knife
- Flat silicone roller

Optional (when metal belt is used)

- EQ-DI - clamp tool
- EQ-DI - metal belt 25 X 0.8
- EQ-DI - hand strapper
- EQ-DI - pneumatic strapper
- EQ-DI - seal

Notes:

- For pipes 16" (400 mm) and larger, two equipped installers are recommended.
- The surface to be covered by the DIRAX should be free from all foreign materials such as dirt, rust, oil, grease and moisture.
- If the pipe is not already factory bevelled, bevel the line coating edges on both sides of the welded joint to 30° or less.

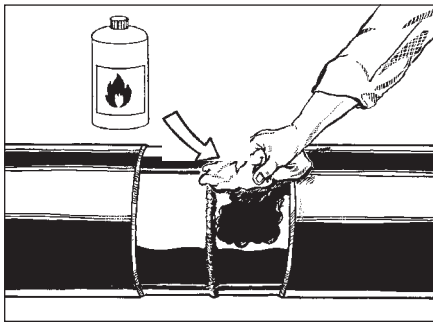

Clean exposed steel and adjacent pipe coating to be covered by DIRAX sleeve. Remove all contaminants such as oil. Use a solvent that contains no grease or oil type materials.

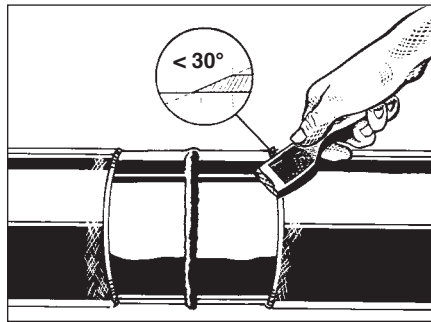

If not factory beveled, chamfer the adjacent pipe coating to an angle of preferably 15°, maximum 30°. Inspect the edge of the existing pipe coating. Disbonded sections have to be trimmed off and the coating edge has to be beveled again. To avoid possible contamination, it is recommended to use a scraper.

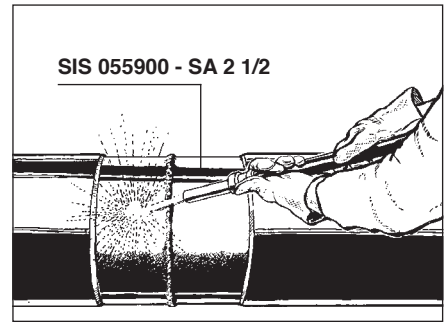

Grid blast or sand blast the steel surface to remove loose and foreign materials. The surface should be cleaned to SIS 055900 - SA 21/2.

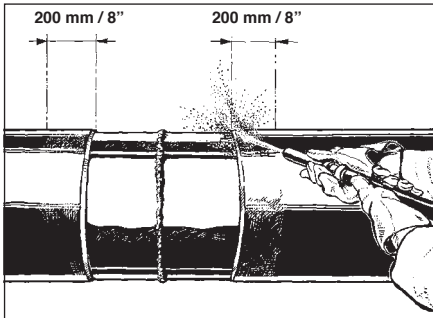

Grid or sand blast the adjacent pipe coating over a distance of at least 200 mm (8"). The total width should be approximately 50 mm larger than the width of the supplied DIRAX sleeve.

Note: prior to blasting, it is recommended to preheat the exposed steel to 40 - 50° C to avoid flash rust formation.

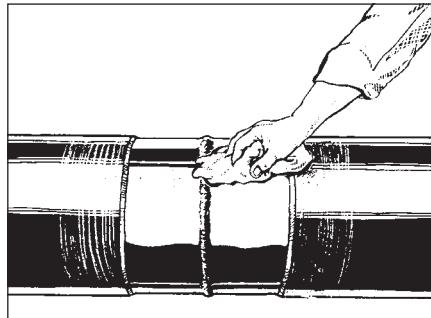

Wipe the surface to remove dust and remaining blasting material. Use a clean dry cloth or air blow.

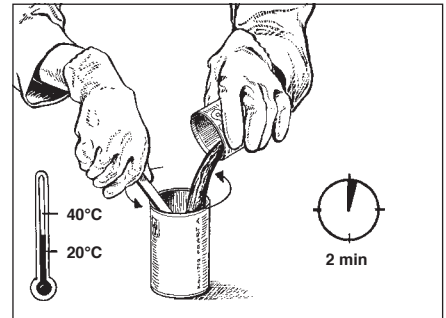

Dose the two component epoxy. Use pre-dosed epoxy kits or use calibrated epoxy pumps.

For pre-dosed epoxy kits, pour content of can B into can A and mix for approximately 1 minute. For easy disposal, it is recommended to pour this mixture back into can B and mix for another 30 seconds. As such, the remaining epoxy in both cans will cure and can be easily disposed off. Follow local regulations for safe disposal.

Mixed epoxy primer has a pot life of approximately 30 minutes at ambient temperature. As long as the epoxy primer is still liquid, it may be used.

For easy mixing and dispensing, the epoxy primer should be used at a temperature of min. 18° C. When necessary, keep the epoxy primer at a heated place or use an epoxy heater.

DIRAX

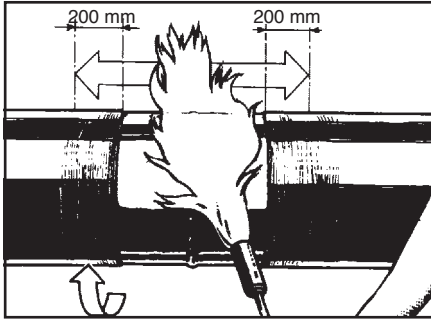

Preheat the bare steel surface and adjacent coating to minimum 70°C (160°F), using propane torches. Adjust flame length to approximately 20" (500 mm). In cold conditions extra heavy preheat torches can be used. Check preheat temperature with a contact pyrometer.

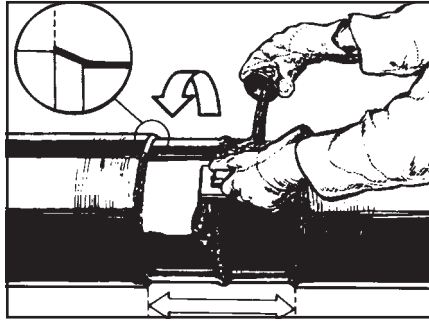

Using the supplied applicator pad, apply the mixed epoxy primer over the entire surface to be covered. (When PE line coating is used, no primer should be applied over the polyethylene line coating.)

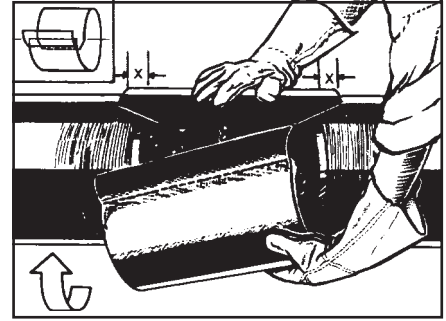

Immediately after application of the epoxy primer, and while the epoxy primer is still wet, loosely wrap the DIRAX sleeve centrally around the welded joint.

If present, remove the protective release plastic from the adhesive side of the DIRAX sleeve.

Wrap the sleeve (adhesive side down) around the area to be coated. Make sure the sleeve overlaps the end of the inner layer by at least 50 mm (2").

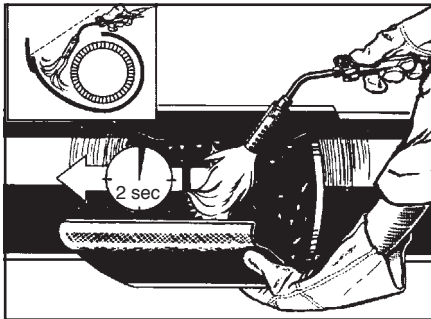

Preheat the inside adhesive layer just next to the closure for a few seconds, and press down on the sleeve end to make it stick to the other end.

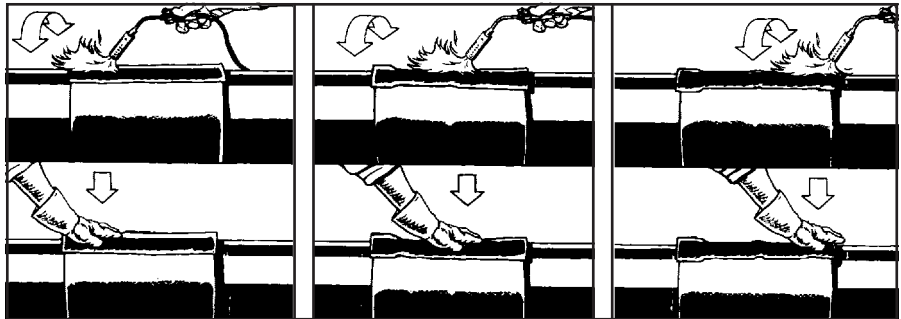

Using a propane torch with a flame length of approximately 500 mm (20"), start heating one end of the closure area.

Immediately pat it down firmly with a gloved hand. Continue heating and patting every 10 cm (4") until the whole patch area is finished.

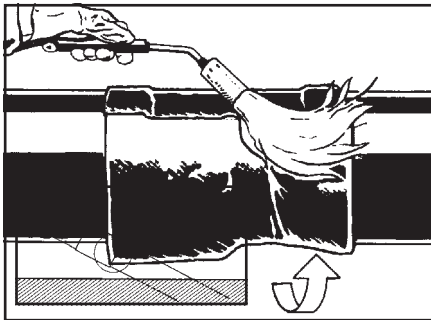

Start heating the sleeve at the side of the leading edge, the side that first comes in contact with the ground forces. Move the torch continuously in a paint brush motion all the way around the sleeve.

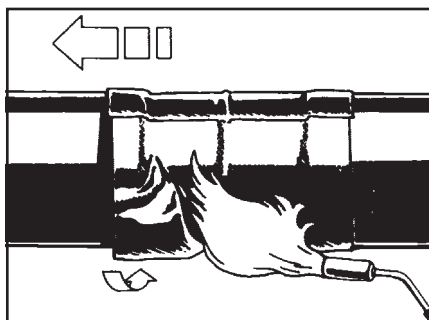

After you have finished heating the side at the leading edge, recover the remainder of the sleeve by heating toward the other end of the sleeve.

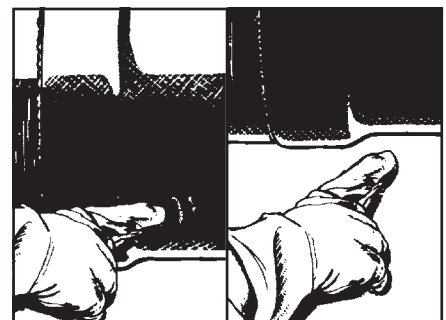

During shrink down, check adhesive flow with finger occasionally. Wrinkles should disappear automatically.

DIRAX

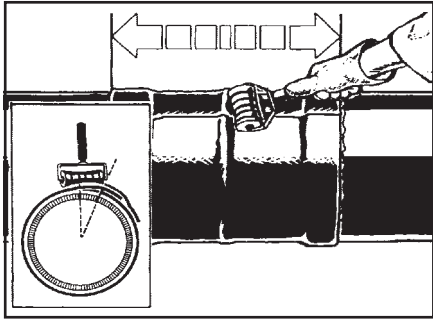

After the DIRAX sleeve has shrunk into the joint area and while it is still hot and soft, run a small hand roller over it to push out any trapped air.

Pay particular attention to the weld and cutback area. Reheat areas if necessary.

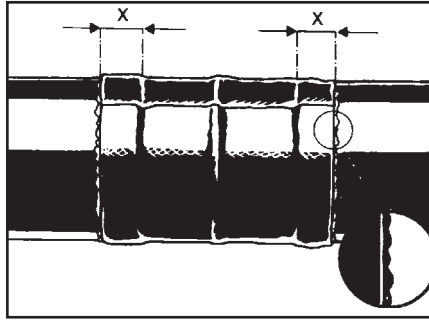

The sleeve is fully recovered when all of the following have occurred:

- The sleeve has fully conformed to the pipe and adjacent coating.
- There are no cold spots or dimples on the sleeve surface.
- Weld bead profile and other step downs can be seen through the sleeve.
- Adhesive flow is evident on both edges, after sleeve is cool.

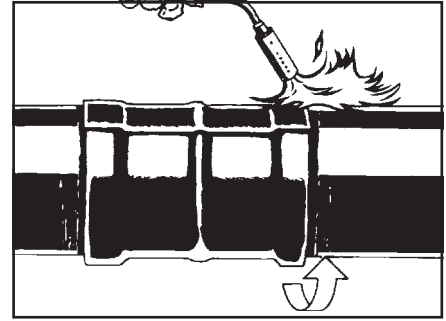

An 80 mm (3.2") wide sacrificial sleeve is installed on the leading edge to function as a wear cone during pull thru of the pipe. Start by heating the leading edge area to 70°C (160°F).

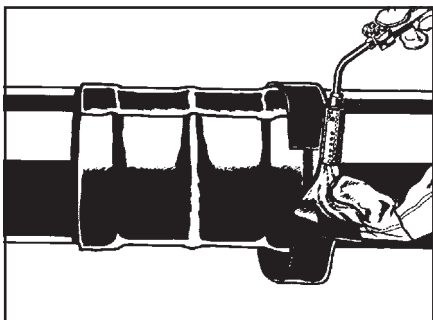

Wrap the leading edge sleeve over the transition DIRAX - mill coating. Make sure that the closure is placed away from the main sleeve closure. Preheat the inside adhesive layer just next to the closure for a few seconds. Press down to make it stick to the other sheet end.

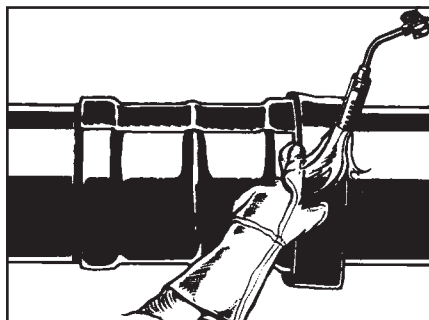

Heat the closure area and immediately pat it down with a gloved hand.

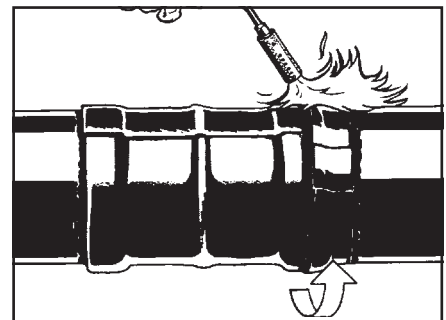

Shrink the leading edge sleeve down by moving the torch all the way around the pipe in a paintbrush motion. Make sure the sleeve has fully shrunk and adhesive flow is evident on both edges.

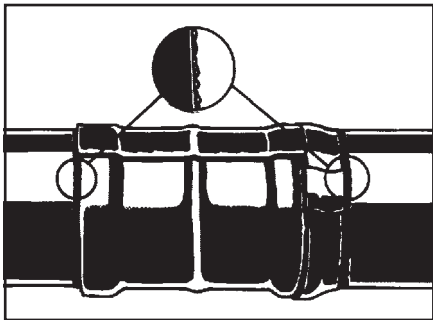

Smooth down the edges of the sleeve with the silicone hand roller.

Sleeve is fully recovered when all the following have occurred:

- The sleeve has fully conformed to the pipe and adjacent coating.
- There are no cold spots or dimples on the sleeve surface.
- Weld bead profile and other step downs can be seen through the sleeve.
- Adhesive flow is evident on both edges after sleeve is cool.

Before the DIRAX can be exposed to the soil forces the joint should be cooled down to ambient temperature.

Berry Plastics warrants that the product conforms to its chemical and physical description and is appropriate for the use stated on the technical data sheet when used in compliance with Berry Plastics written instructions. Since many installation factors are beyond the control of Berry Plastics, the user shall determine the suitability of the products for the intended use and assume all risks and liabilities in connection herewith. Berry Plastics liability is stated in the standard terms and conditions of sale. Berry Plastics makes no other warranty either expressed or implied. All information contained in this technical data sheet is to be used as a guide and is subject to change without notice. This technical data sheet supersedes all previous data sheets on this product.



CORROSION PROTECTION GROUP
www.berrycpg.com

Local Distributor / Representative:

For contact details of local Distributors / Representatives
Please visit www.berrycpg.com.

Headquarters : Berry Plastics Tapes & Coatings Division, Franklin MA, USA

Franklin, MA, USA

Tel: +1 508 918 1714
US Toll Free: +1 800 248 0149
Fax: +1 508 918 1910
CPG@berryplastics.com

Houston, TX, USA

Tel: +1 713 676 0085
US Toll Free: 01 888 676 7202
Fax: +1 713 676 0086
CPGH@berryplastics.com

Tijuana, Mexico

Tel USA +1 858 633 9797
Fax US: +1 858 633 9740
Tel Mexico: +52 664 647 4397
Fax Mexico: +52 664 647 4370
CPGTJ@berryplastics.com

Westerlo, Belgium

Tel. +32 14 722500
Fax +32 14 722570
CPGE@berryplastics.com

Baroda, India

Tel: +91 2667 264721
Fax: +91 2667 264724
CPGIN@berryplastics.com